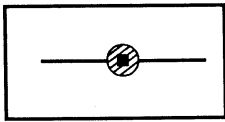

STD & SPEC 3.07

STORM DRAIN
INLET PROTECTIONDefinition

A sediment filter or an excavated impounding area around a storm drain drop inlet or curb inlet.

Purpose

To prevent sediment from entering storm drainage systems prior to permanent stabilization of the disturbed area.

Conditions Where Practice Applies

Where storm drain inlets are to be made operational before permanent stabilization of the corresponding disturbed drainage area. Different types of structures are applicable to different conditions (see Plates 3.07-1 through 3.07-8).

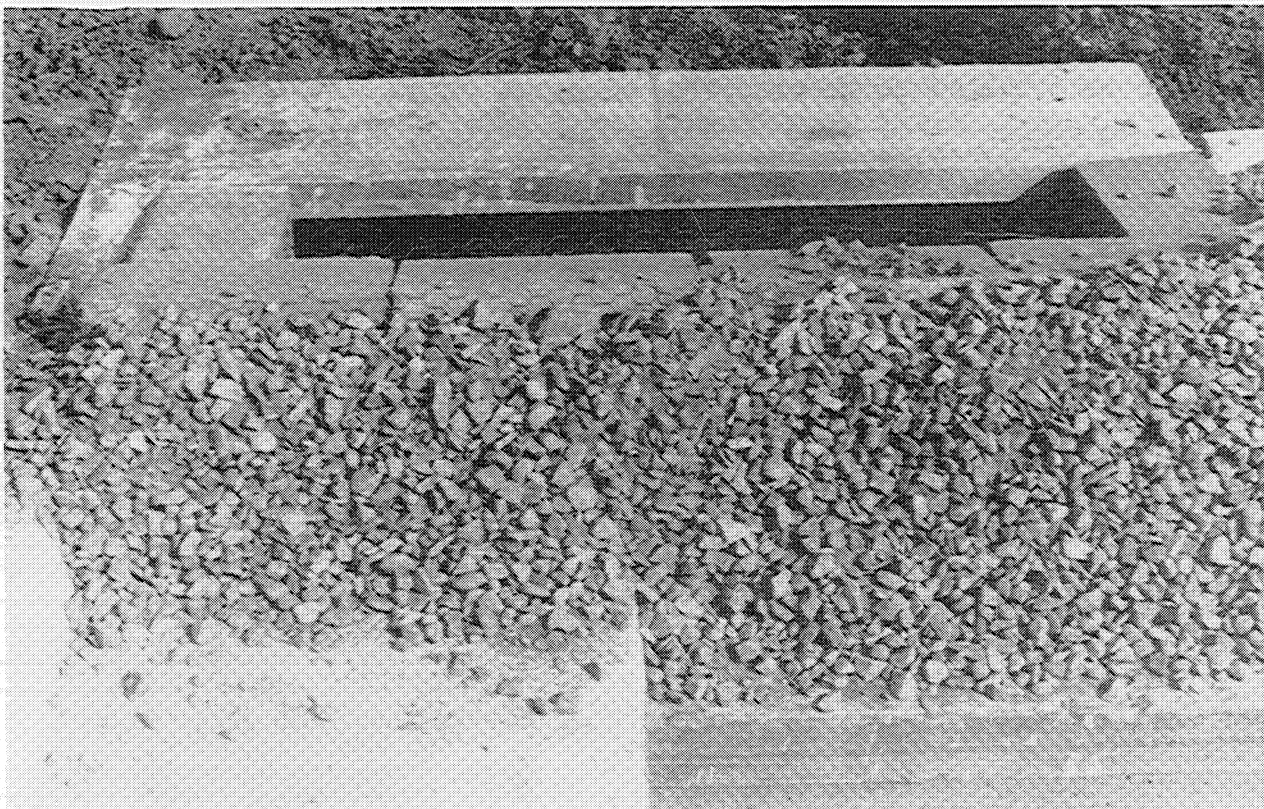

Planning Considerations

Storm sewers which are made operational prior to stabilization of the associated drainage areas can convey large amounts of sediment to natural drainageways. In case of extreme sediment loading, the storm sewer itself may clog and lose a major portion of its capacity. To avoid these problems, it is necessary to prevent sediment from entering the system at the inlets.

This practice contains several types of inlet filters and traps which have different applications dependent upon site conditions and type of inlet. Other innovative techniques for accomplishing the same purpose are encouraged, but only after specific plans and details are submitted to and approved by the appropriate Plan-Approving Authority.

Care should be taken when choosing a specific type of inlet protection. Field experience has shown that inlet protection which causes excessive ponding in an area of high construction activity may become so inconvenient that it is removed or bypassed, thus transmitting sediment-laden flows unchecked. In such situations, a structure with an adequate overflow mechanism should be utilized.

The following inlet protection devices are for drainage areas of one acre or less. Runoff from larger disturbed areas should be routed to a TEMPORARY SEDIMENT TRAP (Std. & Spec. 3.13) or a TEMPORARY SEDIMENT BASIN (Std. & Spec. 3.14).

The best way to prevent sediment from entering the storm sewer system is to stabilize the site as quickly as possible, preventing erosion and stopping sediment at its source.

Stone is utilized as the chief ponding/filtering agent in most of the inlet protection types described in this specification. The various types of "coarse aggregates" which are depicted are able to filter out sediment mainly through slowing down flows directed to the inlet by creating an increased flow path for the stormwater (through void space in the respective stone). The stone filtering medium by no means slows stormwater flowrate as does filter cloth and therefore cannot provide the same degree of filter efficiency when smaller silt and clay particles are introduced into stormwater flows. However, as mentioned earlier, excessive ponding in busy areas adjacent to stormwater inlets is in many cases unacceptable - that is why stone must be utilized with many installations.

Fortunately, in most instances, inlet protection utilizing stone should not be the sole control measure. At the time that storm sewer inlet and associated appurtenances become operational, areas adjacent to the structures are most likely at final grade or will not be altered for extended periods; this is the time when TEMPORARY SEEDING (Std. & Spec. 3.31) and other appropriate controls should be implemented to enhance sediment-loss mitigation. In addition, by varying stone sizes used in the construction of inlet protection, a greater degree of sediment removal can be obtained. As an option, filter cloth can be used with the stone in these devices to further enhance sediment removal. Notably, the potential inconvenience of excessive ponding must be examined with these choices, especially the latter.

Design Criteria

1. The drainage area shall be no greater than 1 acre.
2. The inlet protection device shall be constructed in a manner that will facilitate clean-out and disposal of trapped sediment and minimize interference with construction activities.
3. The inlet protection devices shall be constructed in such a manner that any resultant ponding of stormwater will not cause excessive inconvenience or damage to adjacent areas or structures.
4. Design criteria more specific to each particular inlet protection device will be found on Plates 3.07-1 through 3.07-8.
5. For the inlet protection devices which utilize stone as the chief ponding/filtering medium, a range of stone sizes is offered; VDOT #3, #357, or #5 Coarse Aggregate should be used. The designer/plan reviewer should attempt to get the greatest amount of filtering action possible (by using smaller-sized stone), while not creating significant ponding problems.
6. In all designs which utilize stone with a wire-mesh support as a filtering mechanism, the stone can be completely wrapped with the wire mesh to improve stability and provide easier cleaning.
7. Filter Fabric may be added to any of the devices which utilize "coarse aggregate" stone to significantly enhance sediment removal. The fabric, which must meet the physical requirements noted for "extra strength" found in Table 3.05-B, should be secured between the stone and the inlet (on wire-mesh if it is present). As a result of the significant increase in filter efficiency provided by the fabric, a larger range of stone sizes (VDOT #1, #2 or #3 Coarse Aggregate) may be utilized with such a configuration. The larger stone will help keep larger sediment masses from clogging the cloth. Notably, significant ponding may occur at the inlet if filter cloth is utilized in this manner.

Construction Specifications

1. Silt Fence Drop Inlet Protection
 - a. Silt Fence shall conform to the construction specifications for "extra strength" found in Table 3.05-B and shall be cut from a continuous roll to avoid joints.
 - b. For stakes, use 2 x 4-inch wood (preferred) or equivalent metal with a minimum length of 3 feet.

- c. Space stakes evenly around the perimeter of the inlet a maximum of 3-feet apart, and securely drive them into the ground, approximately 18-inches deep (see Plate 3.07-1).
- d. To provide needed stability to the installation, frame with 2 x 4-inch wood strips around the crest of the overflow area at a maximum of 1½ feet above the drop inlet crest.
- e. Place the bottom 12 inches of the fabric in a trench (see Plate 3.07-1) and backfill the trench with 12 inches of compacted soil.
- f. Fasten fabric securely by staples or wire to the stakes and frame. Joints must be overlapped to the next stake.
- g. It may be necessary to build a temporary dike on the downslope side of the structure to prevent bypass flow.

2. Gravel and Wire Mesh Drop Inlet Sediment Filter

- a. Wire mesh shall be laid over the drop inlet so that the wire extends a minimum of 1 foot beyond each side of the inlet structure. Wire mesh with 1/2-inch openings shall be used. If more than one strip of mesh is necessary, the strips shall be overlapped.
- b. Coarse aggregate shall be placed over the wire mesh as indicated on Plate 3.07-2. The depth of stone shall be at least 12 inches over the entire inlet opening. The stone shall extend beyond the inlet opening at least 18 inches on all sides.
- c. If the stone filter becomes clogged with sediment so that it no longer adequately performs its function, the stones must be pulled away from the inlet, cleaned and/or replaced.

Note: This filtering device has no overflow mechanism; therefore, ponding is likely especially if sediment is not removed regularly. This type of device must never be used where overflow may endanger an exposed fill slope. Consideration should also be given to the possible effects of ponding on traffic movement, nearby structures, working areas, adjacent property, etc.

3. Block and Gravel Drop Inlet Sediment Filter

- a. Place concrete blocks lengthwise on their sides in a single row around the perimeter of the inlet, with the ends of adjacent blocks abutting. The height of the barrier can be varied, depending on design needs, by stacking combinations of 4-inch, 8-inch and 12-inch wide blocks. The barrier of blocks shall be at least 12-inches high and no greater than 24-inches high.

SILT FENCE DROP INLET PROTECTION

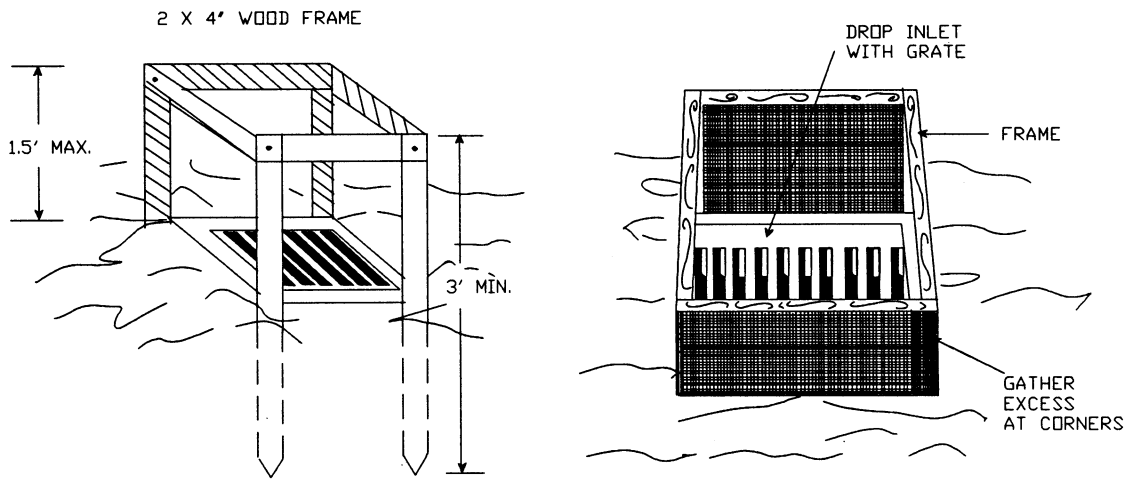

PERSPECTIVE VIEWS

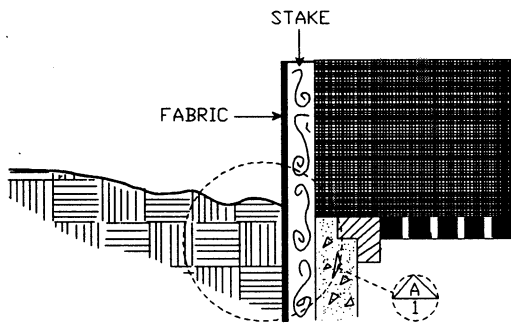

ELEVATION OF STAKE AND FABRIC ORIENTATION

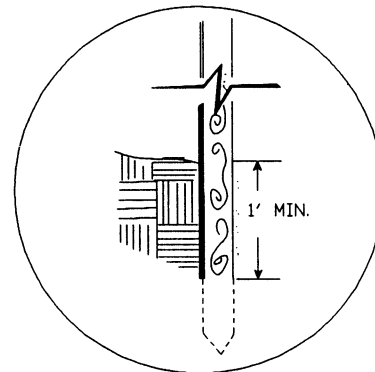

DETAIL A

SPECIFIC APPLICATION

THIS METHOD OF INLET PROTECTION IS APPLICABLE WHERE THE INLET DRAINS A RELATIVELY FLAT AREA (SLOPE NO GREATER THAN 5%) WHERE THE INLET SHEET OR OVERLAND FLOWS (NOT EXCEEDING 1 C.F.S.) ARE TYPICAL. THE METHOD SHALL NOT APPLY TO INLETS RECEIVING CONCENTRATED FLOWS, SUCH AS IN STREET OR HIGHWAY MEDIANS.

Source: N.C. Erosion and Sediment Control Planning and Design Manual, 1988

Plate 3.07-1

GRAVEL AND WIRE MESH DROP INLET SEDIMENT FILTER

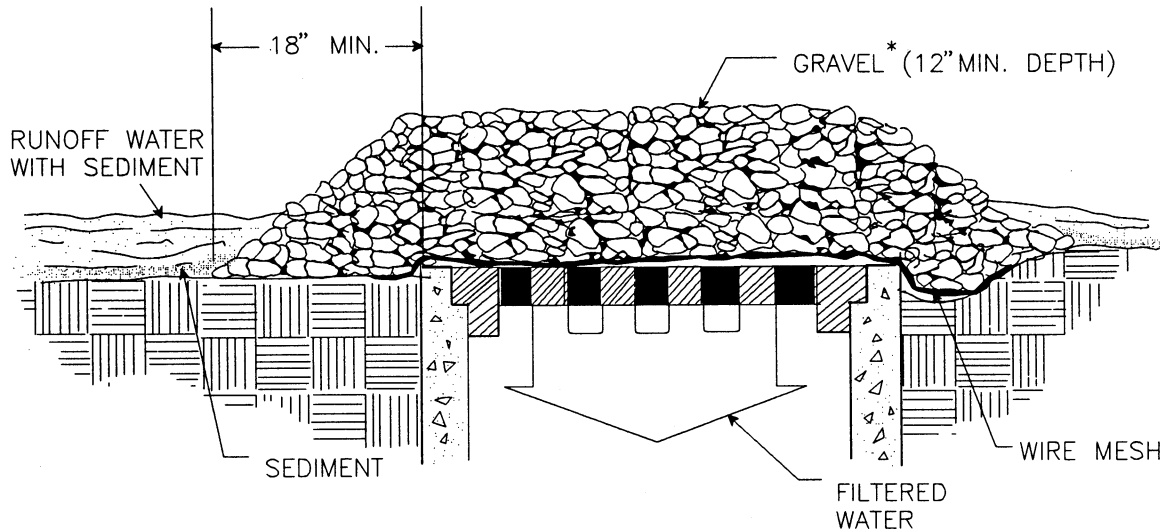

SPECIFIC APPLICATION

THIS METHOD OF INLET PROTECTION IS APPLICABLE WHERE HEAVY CONCENTRATED FLOWS ARE EXPECTED, BUT NOT WHERE PONDING AROUND THE STRUCTURE MIGHT CAUSE EXCESSIVE INCONVENIENCE OR DAMAGE TO ADJACENT STRUCTURES AND UNPROTECTED AREAS.

* GRAVEL SHALL BE VDOT #3, #357 OR #5 COARSE AGGREGATE.

- b. Wire mesh shall be placed over the outside vertical face (webbing) of the concrete blocks to prevent stone from being washed through the holes in the blocks. Wire mesh with 1/2-inch openings shall be used.
- c. Stone shall be piled against the wire to the top of the block barrier, as shown in Plate 3.07-3.
- d. If the stone filter becomes clogged with sediment so that it no longer adequately performs its function, the stone must be pulled away from the blocks, cleaned and replaced.

4. Excavated Drop Inlet Sediment Trap

- a. The excavated trap shall be sized to provide a minimum storage capacity calculated at the rate of 134 cubic yards per acre of drainage area. A trap shall be no less than 1-foot nor more than 2-feet deep measured from the top of the inlet structure. Side slopes shall not be steeper than 2:1 (see Plate 3.07-4).
- b. The slope of the basin may vary to fit the drainage area and terrain. Observations must be made to check trap efficiency and modifications shall be made as necessary to ensure satisfactory trapping of sediment. Where an inlet is located so as to receive concentrated flows, such as in a highway median, it is recommended that the basin have a rectangular shape in a 2:1 (length/width) ratio, with the length oriented in the direction of the flow.
- c. Sediment shall be removed and the trap restored to its original dimensions when the sediment has accumulated to one-half the design depth of the trap. Removed sediment shall be deposited in a suitable area and in a manner such that it will not erode.

5. Sod Drop Inlet Sediment Filter

- a. Soil shall be prepared and sod installed according to the specifications in Std. & Spec. 3.33, SODDING.
- b. Sod shall be placed to form a turf mat covering the soil for a distance of 4 feet from each side of the inlet structure, as depicted in Plate 3.07-5.

6. Gravel Curb Inlet Sediment Filter

- a. Wire mesh with 1/2-inch openings shall be placed over the curb inlet opening so that at least 12 inches of wire extends across the inlet cover and at least 12 inches of wire extends across the concrete gutter from the inlet opening, as depicted in Plate 3.07-6.

BLOCK AND GRAVEL DROP INLET SEDIMENT FILTER

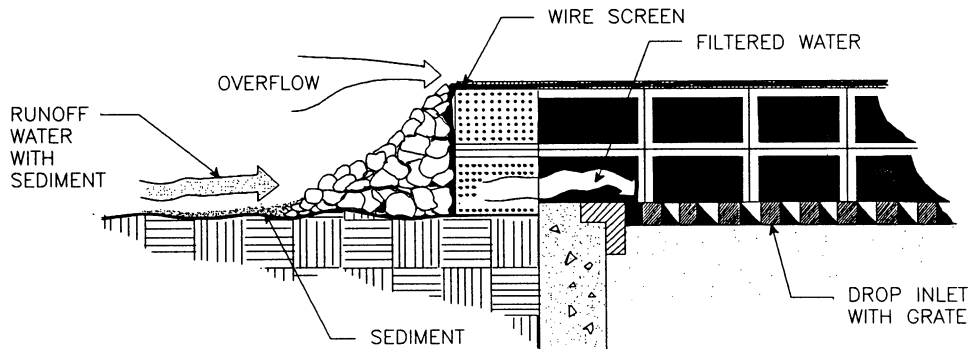
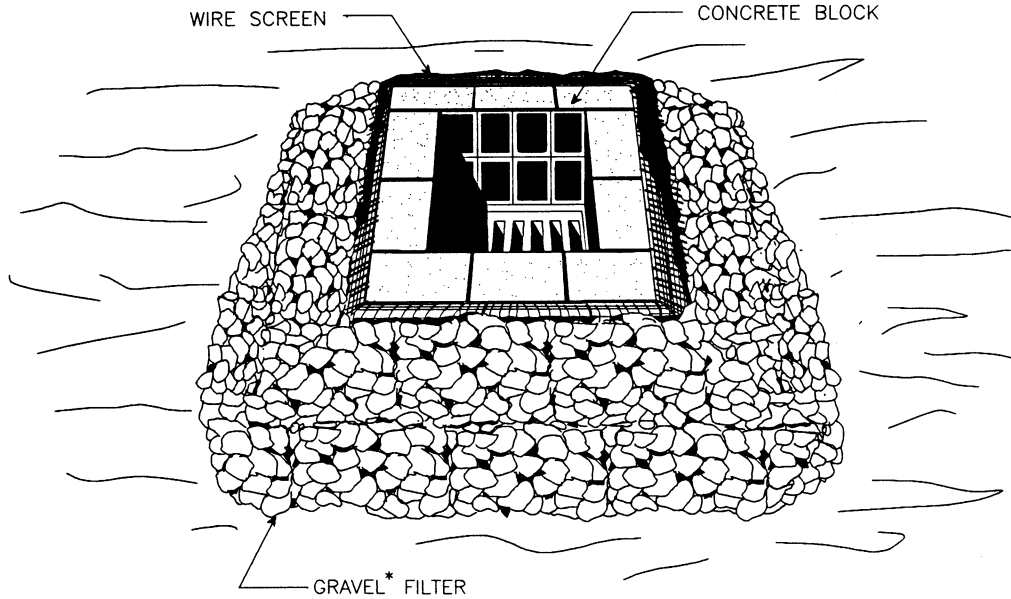

SPECIFIC APPLICATION

THIS METHOD OF INLET PROTECTION IS APPLICABLE WHERE HEAVY FLOWS ARE EXPECTED AND WHERE AN OVERFLOW CAPACITY IS NECESSARY TO PREVENT EXCESSIVE PONDING AROUND THE STRUCTURE.

* GRAVEL SHALL BE VDOT #3, #357 OR #5 COARSE AGGREGATE.

EXCAVATED DROP INLET SEDIMENT TRAP

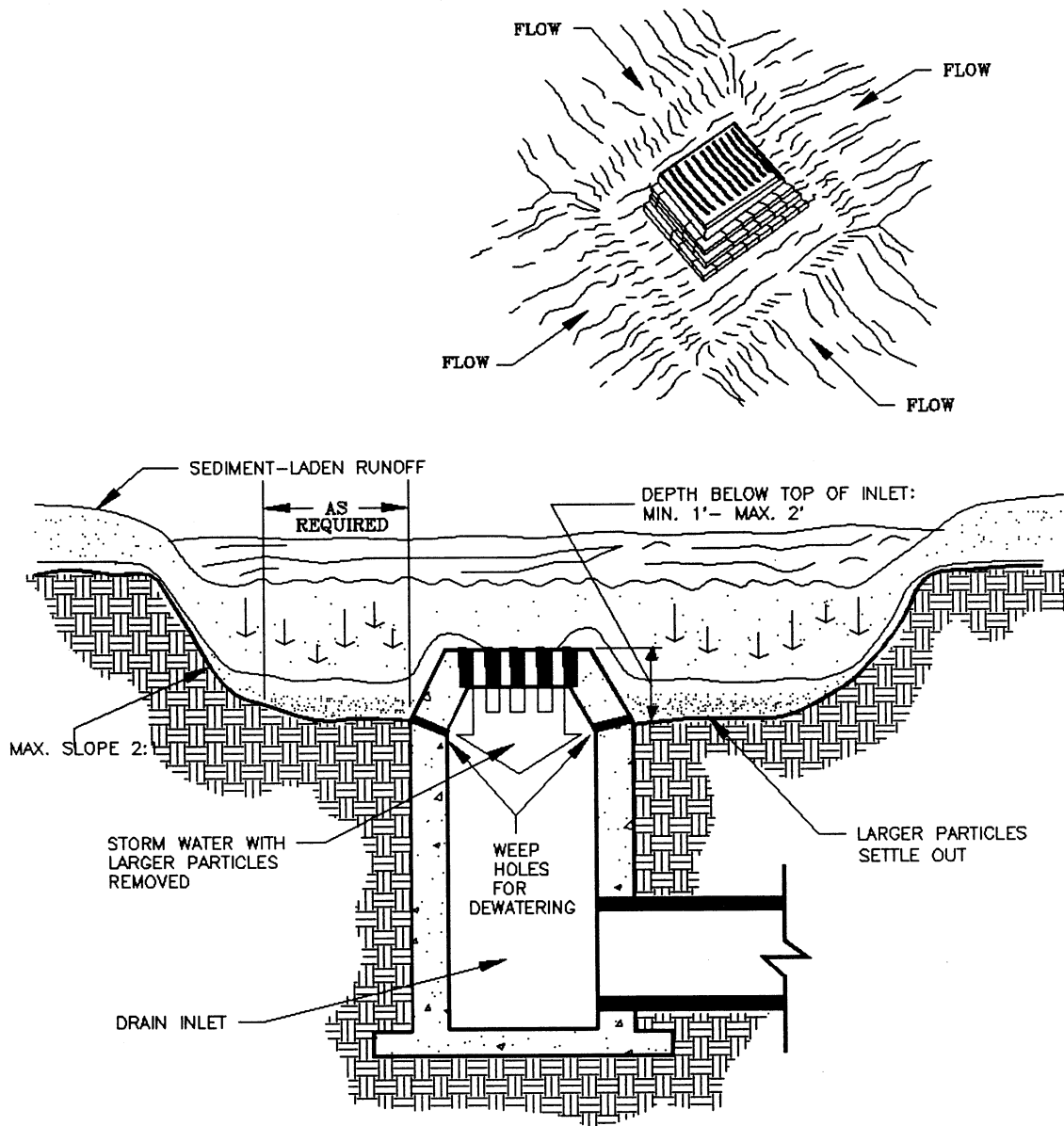

SPECIFIC APPLICATION

THIS METHOD OF INLET PROTECTION IS APPLICABLE WHERE HEAVY FLOWS ARE EXPECTED AND WHERE AN OVERFLOW CAPABILITY AND EASE OF MAINTENANCE ARE DESIRABLE.

Source: Michigan Soil Erosion and Sediment Control Guidebook, 1975, and USDA-SCS

Plate 3.07-4

SOD DROP INLET SEDIMENT FILTER

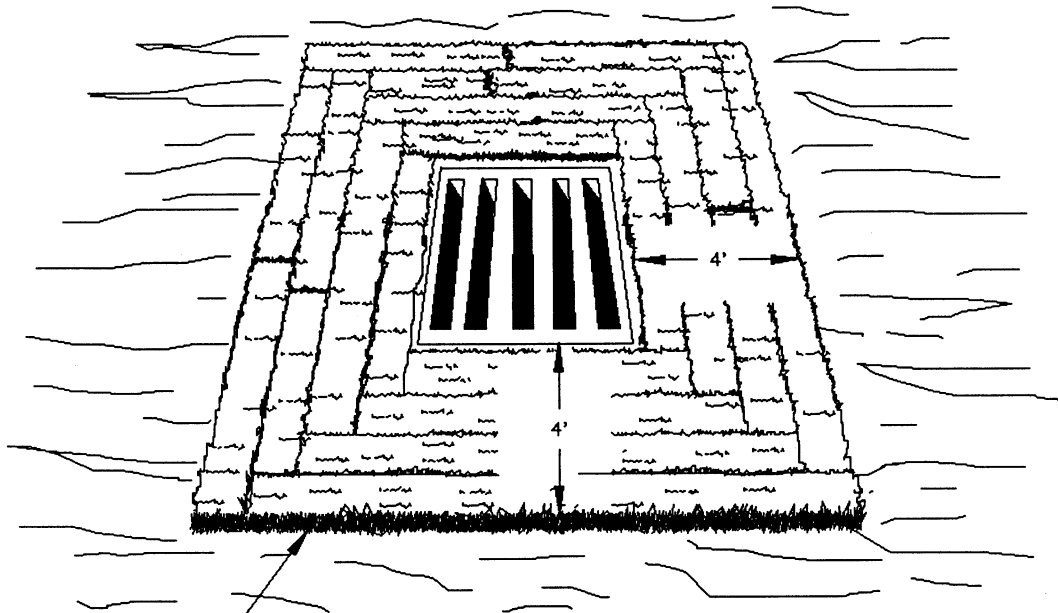

FOUR 1-FOOT WIDE STRIPS OF SOD ON EACH SIDE OF THE DROP INLET

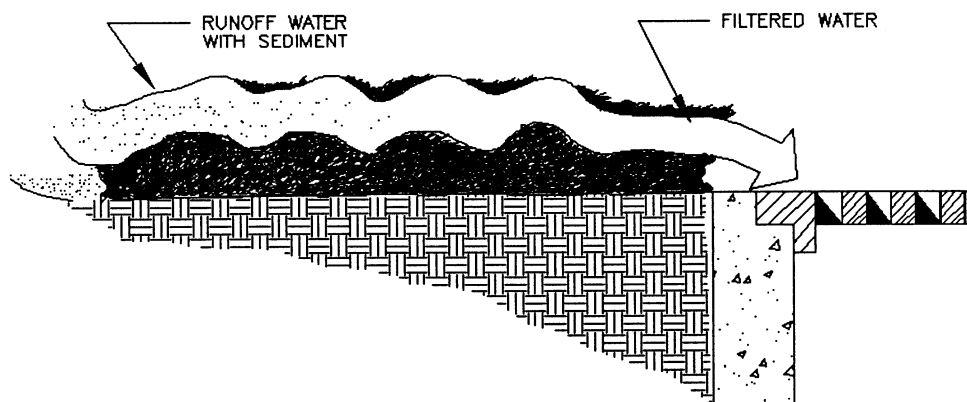

SPECIFIC APPLICATION

THIS METHOD OF INLET PROTECTION IS APPLICABLE ONLY AT THE TIME OF PERMANENT SEEDING, TO PROTECT THE INLET FROM SEDIMENT AND MULCH MATERIAL UNTIL PERMANENT VEGETATION HAS BECOME ESTABLISHED.

GRAVEL CURB INLET SEDIMENT FILTER

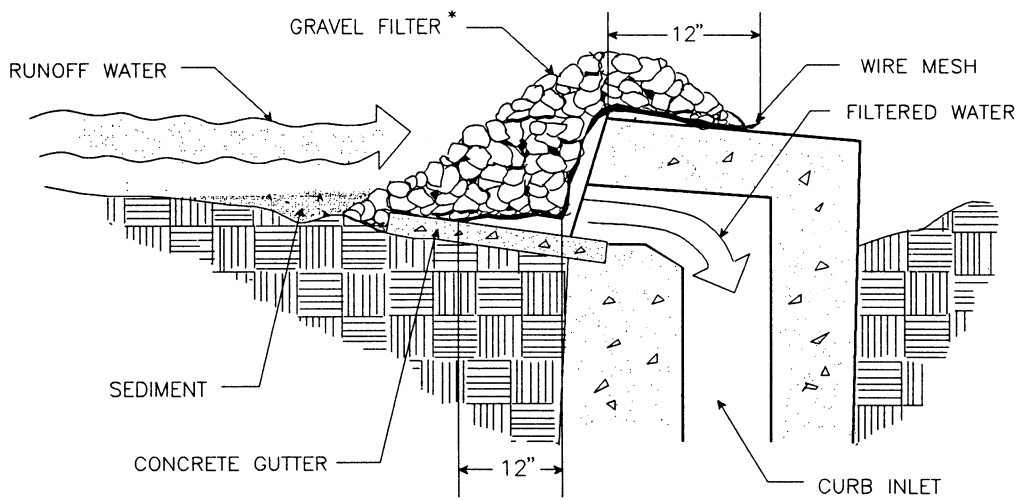
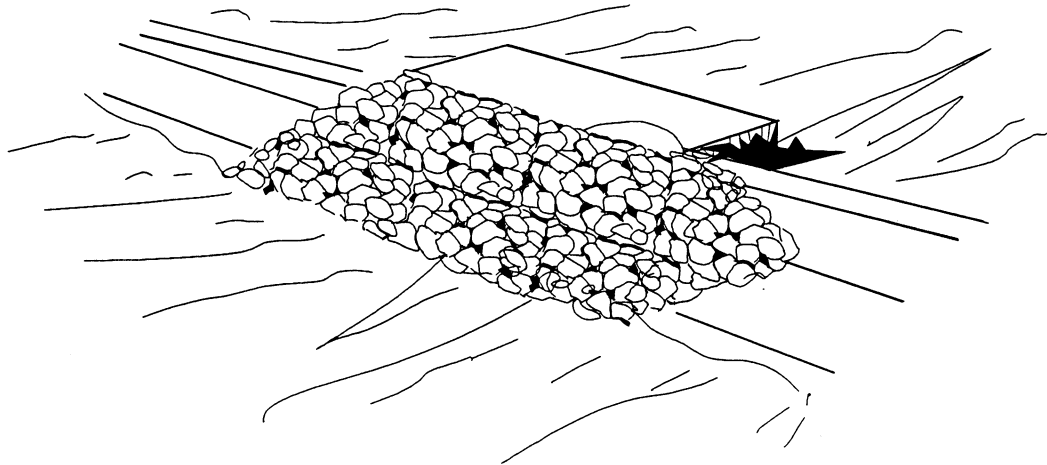

SPECIFIC APPLICATION

THIS METHOD OF INLET PROTECTION IS APPLICABLE AT CURB INLETS WHERE PONDING IN FRONT OF THE STRUCTURE IS NOT LIKELY TO CAUSE INCONVENIENCE OR DAMAGE TO ADJACENT STRUCTURES AND UNPROTECTED AREAS.

* GRAVEL SHALL BE VDOT #3, #357 OR 5 COARSE AGGREGATE.

- b. Stone shall be piled against the wire so as to anchor it against the gutter and inlet cover and to cover the inlet opening completely.
- c. If the stone filter becomes clogged with sediment so that it no longer adequately performs its function, the stone must be pulled away from the block, cleaned and replaced.

7. Curb Inlet Protection with 2-inch x 4-inch Wooden Weir

- a. Attach a continuous piece of wire mesh (30-inch minimum width x inlet throat length plus 4 feet) to the 2-inch x 4-inch wooden weir (with a total length of throat length plus 2 feet) as shown in Plate 3.07-7. Wood should be "construction grade" lumber.
- b. Place a piece of approved "extra-strength" filter cloth of the same dimensions as the wire mesh over the wire mesh and securely attach to the 2-inch x 4-inch weir.
- c. Securely nail the 2-inch x 4-inch weir to the 9-inch long vertical spacers which are to be located between the weir and inlet face at a maximum 6-foot spacing.
- d. Place the assembly against the inlet throat and nail 2-foot (minimum) lengths of 2-inch x 4-inch board to the top of the weir at spacer locations. These 2-inch x 4-inch anchors shall extend across the inlet tops and be held in place by sandbags or alternate weight.
- e. The assembly shall be placed so that the end spacers are a minimum 1 foot beyond both ends of the throat opening.
- f. Form the wire mesh and filter cloth to the concrete gutter and against the face of curb on both sides of the inlet. Place coarse aggregate over the wire mesh and filter fabric in such a manner as to prevent water from entering the inlet under or around the filter cloth.
- g. This type of protection must be inspected frequently and the filter cloth and stone replaced when clogged with sediment.
- h. Assure that storm flow does not bypass inlet by installing temporary earth or asphalt dikes directing flow into inlet.

8. Block and Gravel Curb Inlet Sediment Filter

- a. Two concrete blocks shall be placed on their sides abutting the curb at either side of the inlet opening.

CURB INLET PROTECTION WITH 2-INCH X 4-INCH WOODEN WEIR

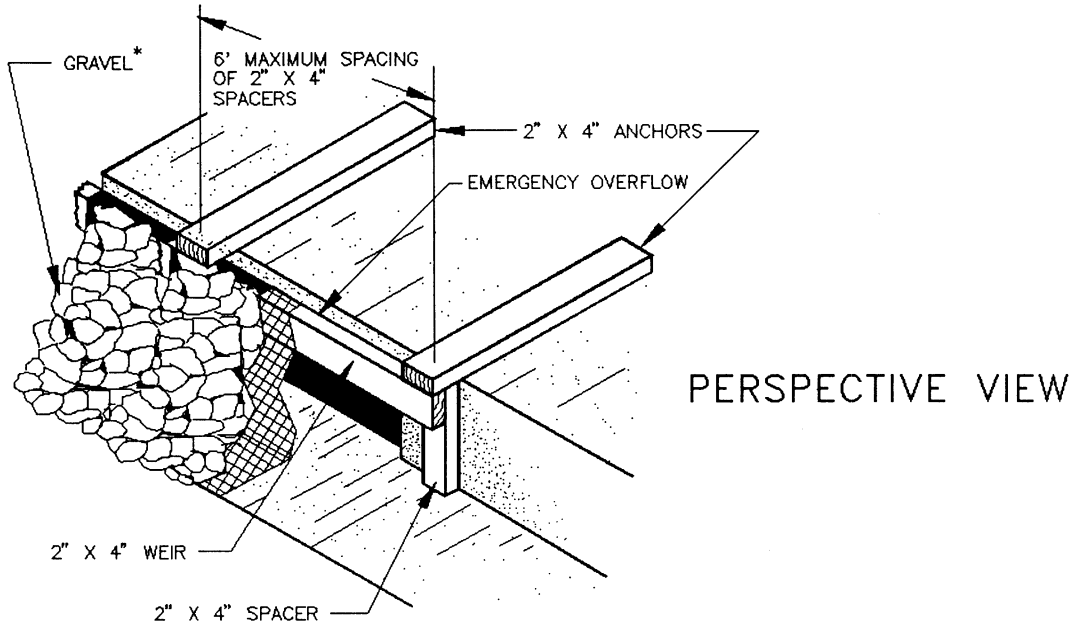

PERSPECTIVE VIEW

SIDE ELEVATION

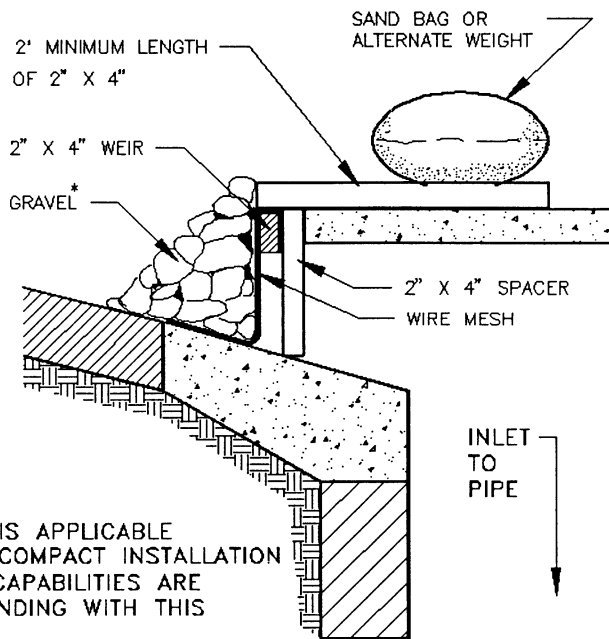

SPECIFIC APPLICATION

THIS METHOD OF INLET PROTECTION IS APPLICABLE TO CURB INLETS WHERE A STURDY, COMPACT INSTALLATION IS DESIRED. EMERGENCY OVERFLOW CAPABILITIES ARE MINIMAL, SO EXPECT SIGNIFICANT PONDING WITH THIS MEASURE.

* GRAVEL SHALL BE VDOT COARSE AGGREGATE #3, #357 OR #5

Source: 1983 Maryland Standards and Specifications for Soil Erosion and Sediment Control, and USDA-SCS

Plate 3.07-7

- b. A 2-inch x 4-inch stud shall be cut and placed through the outer holes of each spacer block to help keep the front blocks in place.
- c. Concrete blocks shall be placed on their sides across the front of the inlet and abutting the spacer blocks as depicted in Plate 3.07-8.
- d. Wire mesh shall be placed over the outside vertical face (webbing) of the concrete blocks to prevent stone from being washed through the holes in the blocks. Wire mesh with 1/2-inch openings shall be used.
- e. Coarse aggregate shall be piled against the wire to the top of the barrier as shown in Plate 3.07-8.
- f. If the stone filter becomes clogged with sediment so that it no longer adequately performs its function, the stone must be pulled away from the blocks, cleaned and/or replaced.

Maintenance

1. The structure shall be inspected after each rain and repairs made as needed.
2. Sediment shall be removed and the trap restored to its original dimensions when the sediment has accumulated to one half the design depth of the trap. Removed sediment shall be deposited in a suitable area and in such a manner that it will not erode.
3. Structures shall be removed and the area stabilized when the remaining drainage area has been properly stabilized.

BLOCK & GRAVEL CURB INLET SEDIMENT FILTER

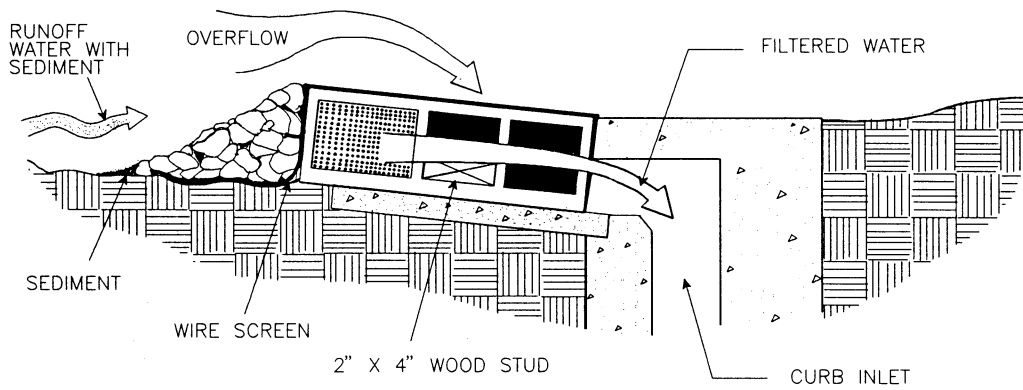
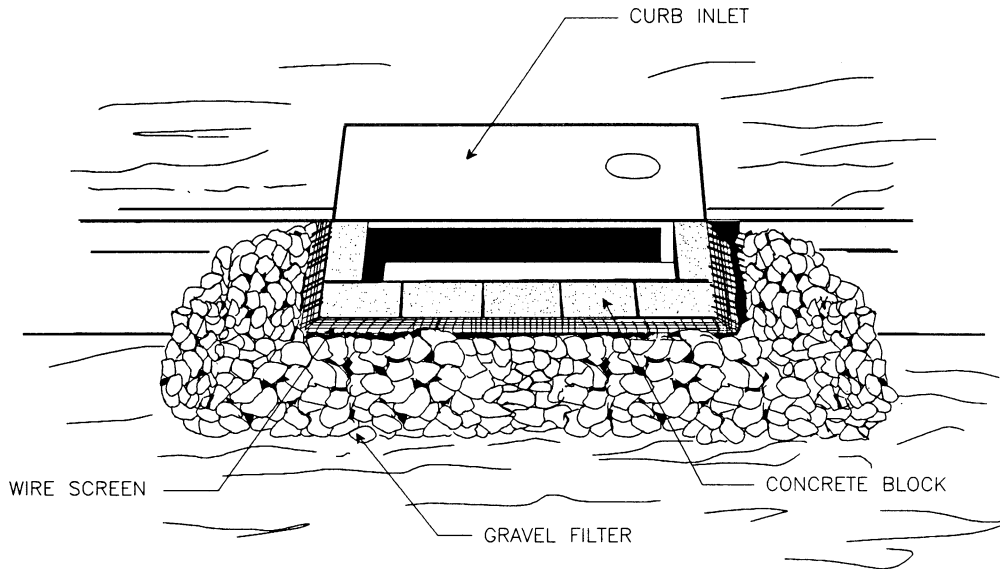

SPECIAL APPLICATION

THIS METHOD OF INLET PROTECTION IS APPLICABLE AT CURB INLETS WHERE AN OVERFLOW CAPABILITY IS NECESSARY TO PREVENT EXCESSIVE PONDING IN FRONT OF THE STRUCTURE.

* GRAVEL SHALL BE VDOT #3, #357 OR #5 COARSE AGGREGATE