

STD & SPEC 3.13

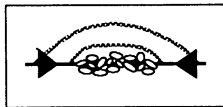

TEMPORARY SEDIMENT TRAP

Definition

A temporary ponding area formed by constructing an earthen embankment with a stone outlet.

Purpose

To detain sediment-laden runoff from small disturbed areas long enough to allow the majority of the sediment to settle out.

Conditions Where Practice Applies

1. Below disturbed areas where the total contributing drainage area is less than 3 acres.



2. Where the sediment trap will be used no longer than 18 months (the maximum useful life is 18 months).
3. The sediment trap may be constructed either independently or in conjunction with a TEMPORARY DIVERSION DIKE (Std. & Spec. 3.09).

Planning Considerations

Sediment traps should be used only for small drainage areas. If the contributing drainage area is 3 acres or greater, refer to SEDIMENT BASIN (Std. & Spec. 3.14).

Sediment traps, along with other perimeter controls intended to trap sediment, shall be constructed as a first step in any land-disturbing activity and shall be made functional before upslope land disturbance takes place.

Recent studies have been conducted on the performance of sediment traps (and basins) which were constructed using the design criteria found in previous editions of this handbook. The studies indicate that the control measures only achieved a 46% removal of sediment which flowed into them during storm events which caused measurable outflow. To achieve a more acceptable removal rate (60%), it was necessary to revise the design of these measures in this handbook. The total initial storage volume for both the sediment trap and the TEMPORARY SEDIMENT BASIN (Std. & Spec. 3.14) has been doubled. There are both a "wet" storage volume and a drawdown or "dry" storage volume which help to enhance sediment fall-out and prevent excessive sediment losses during large storm events which occur during the advanced stages of land disturbance (28).

In most cases excavation will be required to attain the necessary storage volume. Also, sediment must be periodically removed from the trap to maintain the required volume. Plans should detail how excavated sediment is to be disposed of, such as by use in fill areas on site or removal to an approved off-site location.

As noted previously in this handbook, there are numerous other acceptable ways to design many of the erosion control practices within. This is certainly true in the case of the sediment trap. However, variations in its design should be considered judiciously by plan reviewers to ensure that the minimum storage requirements and structural integrity noted in this specification are maintained.

Design Criteria

Trap Capacity

The sediment trap must have an initial storage volume of 134 cubic yards per acre of drainage area, half of which shall be in the form of a permanent pool or wet storage to provide a stable settling medium. The remaining half shall be in the form of a drawdown

or dry storage which will provide extended settling time during less frequent, larger storm events. The volume of the wet storage shall be measured from the low point of the excavated area to the base of the stone outlet structure. The volume of the dry storage shall be measured from the base of the stone outlet to the crest of the stone outlet (overflow mechanism). Sediment should be removed from the basin when the volume of the wet storage is reduced by one-half.

For a sediment trap, the wet storage volume may be approximated as follows:

$$V_1 = 0.85 \times A_1 \times D_1$$

where,

V_1 = the wet storage volume in cubic feet

A_1 = the surface area of the flooded area at the base of the stone outlet in square feet

D_1 = the maximum depth in feet, measured from the low point in the trap to the base of the stone outlet

The dry storage volume may be approximated as follows:

$$V_2 = \frac{A_1 + A_2}{2} \times D_2$$

where,

V_2 = the dry storage volume in cubic feet

A_1 = the surface area of the flooded area at the base of the stone outlet in square feet

A_2 = the surface area of the flooded area at the crest of the stone outlet (overflow mechanism), in square feet

D_2 = the depth in feet, measured from the base of the stone outlet to the crest of the stone outlet

The designer should seek to provide a storage area which has a minimum 2:1 length to width ratio (measured from point of maximum runoff introduction to outlet).

Note: Conversion between cubic feet and cubic yards is as follows:

$$\text{number of cubic feet} \times 0.037 = \text{number of cubic yards}$$

Excavation

Side slopes of excavated areas should be no steeper than 1:1. The maximum depth of excavation within the wet storage area should be 4 feet to facilitate clean-out and for site safety considerations.

Outlet

The outlet for the sediment trap shall consist of a stone section of the embankment located at the low point in the basin. A combination of coarse aggregate and riprap shall be used to provide for filtering/detention as well as outlet stability. The smaller stone shall be VDOT #3, #357, or #5 Coarse Aggregate (smaller stone sizes will enhance filter efficiency) and riprap shall be "Class I." Filter cloth which meets the physical requirements noted in Std. & Spec. 3.19, RIPRAP shall be placed at the stone-soil interface to act as a "separator." The minimum length of the outlet shall be 6 feet times the number of acres comprising the total area draining to the trap. The crest of the stone outlet must be at least 1.0 foot below the top of the embankment to ensure that the flow will travel over the stone and not the embankment. The outlet shall be configured as noted in Plate 3.13-2.

Embankment Cross-Section

The maximum height of the sediment trap embankment shall be 5 feet as measured from the base of the stone outlet. Minimum top widths (W) and outlet heights (Ho) for various embankment heights (H) are shown in Plate 3.13-1. Side slopes of the embankment shall be 2:1 or flatter.

Removal

Sediment traps must be removed after the contributing drainage area is stabilized. Plans should show how the site of the sediment trap is to be graded and stabilized after removal.

Construction Specifications

1. The area under the embankment shall be cleared, grubbed, and stripped of any vegetation and root mat.
2. Fill material for the embankment shall be free of roots or other woody vegetation, organic material, large stones, and other objectionable material. The embankment should be compacted in 6-inch layers by traversing with construction equipment.

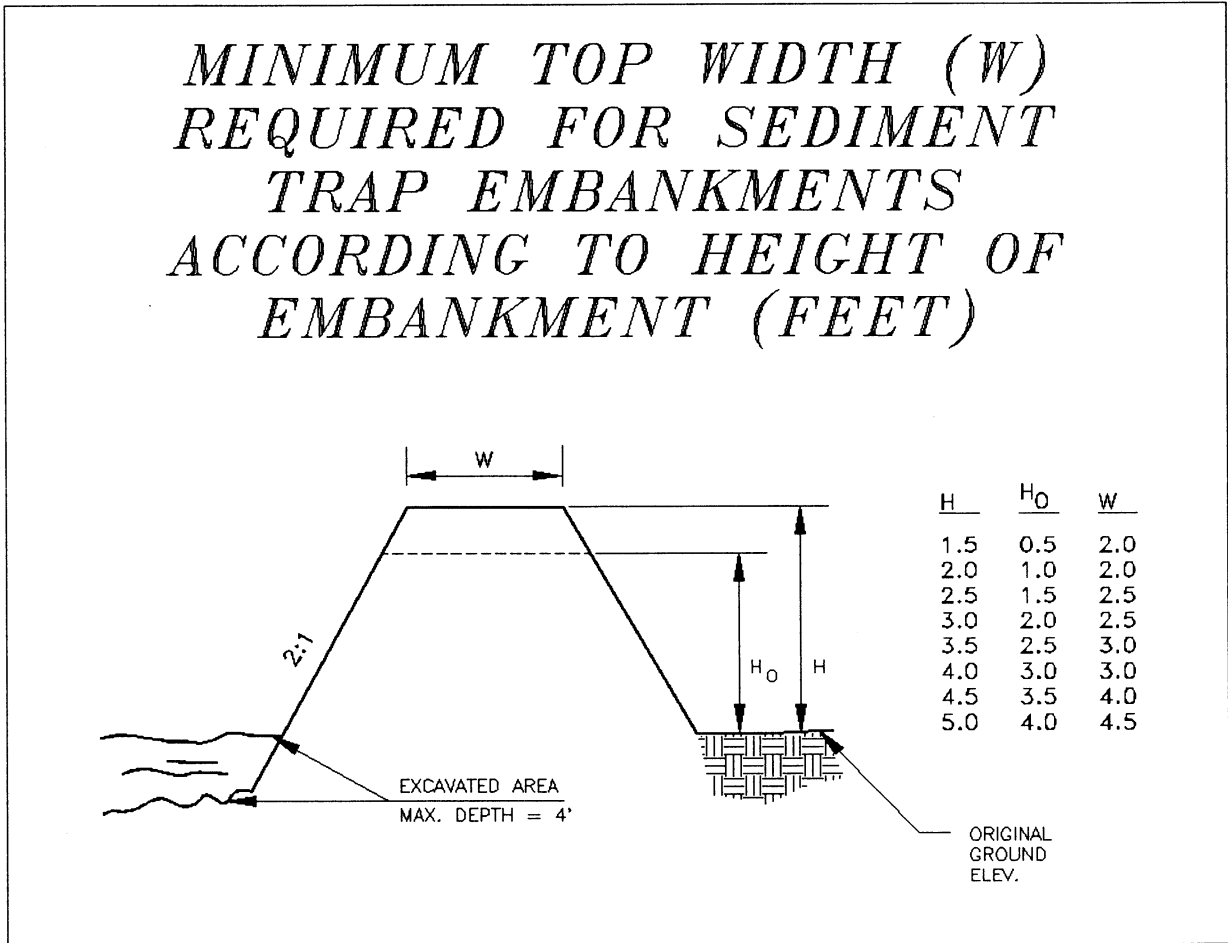

Source: Va. DSWC

Plate 3.13-1

3. The earthen embankment shall be seeded with temporary or permanent vegetation (see Std. & Spec.'s 3.31 and 3.32) immediately after installation.
4. Construction operations shall be carried out in such a manner that erosion and water pollution are minimized.
5. The structure shall be removed and the area stabilized when the upslope drainage area has been stabilized.
6. All cut and fill slopes shall be 2:1 or flatter (except for excavated, wet storage area which may be at a maximum 1:1 grade).

Maintenance

1. Sediment shall be removed and the trap restored to its original dimensions when the sediment has accumulated to one half the design volume of the wet storage. Sediment removal from the basin shall be deposited in a suitable area and in such a manner that it will not erode and cause sedimentation problems.
2. Filter stone shall be regularly checked to ensure that filtration performance is maintained. Stone choked with sediment shall be removed and cleaned or replaced.
3. The structure should be checked regularly to ensure that it is structurally sound and has not been damaged by erosion or construction equipment. The height of the stone outlet should be checked to ensure that its center is at least 1 foot below the top of the embankment.

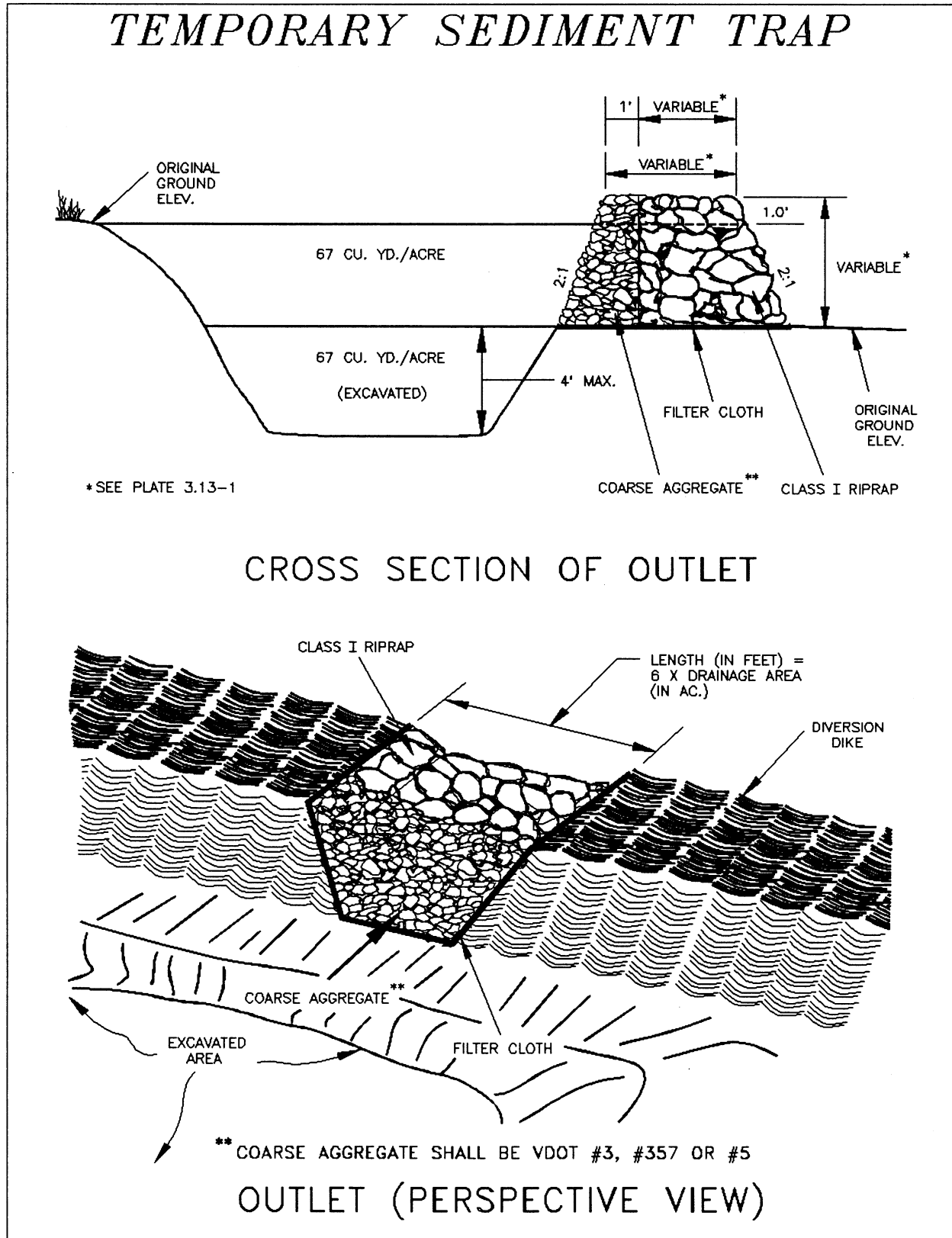

Source: Va. DSWC

Plate 3.13-2