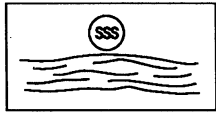

STD & SPEC 3.23

STRUCTURAL STREAMBANK
STABILIZATIONDefinition

Methods of stabilizing the banks of live streams with permanent structural measures.

Purpose

To protect streambanks from the erosive forces of flowing water.

Conditions Where Practice Applies

Applicable to streambank sections which are subject to excessive erosion due to increased flows or disturbance during construction. Generally applicable where flow velocities exceed 5 ft./sec. or where vegetative streambank protection is inappropriate.



Planning Considerations

Stream channel erosion problems vary widely in type and scale and there are many different structural stabilization techniques which have been employed with varying degrees of effectiveness. The purpose of this specification is merely to point out some of the practices which are available and to establish some broad guidelines for their selection and design. Such structures should be planned and designed in advance by an engineer or some other qualified individual with appropriate experience. Many of the practices referenced here involve the use of manufactured products and should be designed and installed in accordance with the manufacturers' specifications.

Before selecting a structural stabilization technique, the designer should carefully evaluate the possibility of using vegetative stabilization (Std. & Spec. 3.22) alone or in conjunction with structural measures, to achieve the desired protection. Vegetative techniques are generally less costly and more compatible with natural stream characteristics.

General Guidelines

Since each reach of channel requiring protection is unique, measures for streambank protection should be installed according to a plan and adapted to the specific site. Designs should be developed according to the following principles:

1. Protective measures to be applied shall be compatible with improvements planned or being carried out by others.
2. The bottom scour should be controlled, by either natural or artificial means, before any permanent type of bank protection can be considered feasible. This is not necessary if the protection can be safely and economically constructed to a depth well below the anticipated lowest depth of bottom scour.
3. Streambank protection should be started and ended at a stabilized or controlled point on the stream.
4. Changes in channel alignment shall be made only after an evaluation of the effect upon land use, interdependent waste water systems, hydraulic characteristics and existing structures.
5. Special attention should be given to maintaining and improving habitat for fish and wildlife.
6. The design velocity should be that of the peak discharge of the 10-year storm. Structural measures must be effective for this design flow and must be capable of withstanding greater flows without serious damage.

7. All requirements of state law and permit requirements of local, state and federal agencies must be met.
8. Stabilize all areas disturbed by construction as soon as the structural measures are complete.

Streambank Protection Measures

Riprap - heavy angular stone placed (preferably) or dumped onto the streambank to provide armor protection against erosion. Riprap shall be designed and installed according to the practice entitled RIPRAP (Std. & Spec. 3.19).

Gabions - rectangular, rock-filled wire baskets are pervious, semi-flexible building blocks which can be used to armor the bed and/or banks of channels or to divert flow away from eroding channel sections. Gabions should be designed and installed in accordance with manufacturer's standards and specifications (see Plate 3.23-1). At a minimum, they should be constructed of a hexagonal triple twist mesh of heavily galvanized steel wire (galvanized wire may also receive a poly-vinyl chloride coating). The design water velocity for channels utilizing gabions should not exceed that given below:

<u>Gabion Thickness (feet)</u>	<u>Maximum Velocity (feet per second)</u>
1/2	6
3/4	11
1	14

Deflectors (groins or jetties) - Structural barriers which project into the stream to divert flow away from eroding streambank sections. Plate 3.23-2 contains general guidelines for designing and installing deflectors.

Installation of Structures Under Wave and/or Tidal Action

The installation of riprap, gabions or deflectors under significant wave action or under tidal conditions requires special design considerations to ensure stability of the measure and the area it protects. The design/installation of these measures for tidal areas is beyond the scope of the Virginia Erosion and Sediment Control Law and Virginia Erosion and Sediment Control Regulations. The DSWC's Shoreline Programs Bureau can be consulted in regard to minimum design parameters for tidal installations. For situations where there

is significant wave action affecting the shoreline of a nontidal lake or pond, the design parameters presented in Std. & Spec. 3.19, RIPRAP, should be used. Notably, there are many other site specific factors which should be incorporated into a design; hence, it is recommended that the design parameters presented only be used as minimum requirements and that a qualified professional be consulted when the installation of such a structure is contemplated.

Reinforced Concrete - may be used to armor eroding sections of the streambank by constructing retaining walls or bulk heads. Positive drainage behind these structures must be provided. Reinforced concrete may also be used as a channel lining (see Std. & Spec. 3.17, STORMWATER CONVEYANCE CHANNEL).

Log Cribbing - a retaining structure built of logs to protect streambanks from erosion. Log cribbing is normally built on the outside of stream bends to protect the streambank from the impinging flow of the stream (see Plate 3.23-3).

Grid Pavers - modular concrete units with interspersed void areas which can be used to armor the streambank while maintaining porosity and allowing the establishment of vegetation. These structures may be obtained in pre-cast blocks or mats, or they may be formed and poured in place. Design and installation should be in accordance with manufacturer's instructions (see Plate 3.23-4).

Maintenance

All structures should be maintained in an "as built" condition. Structural damage caused by storm events should be repaired as soon as possible to prevent further damage to the structure or erosion of the streambank.

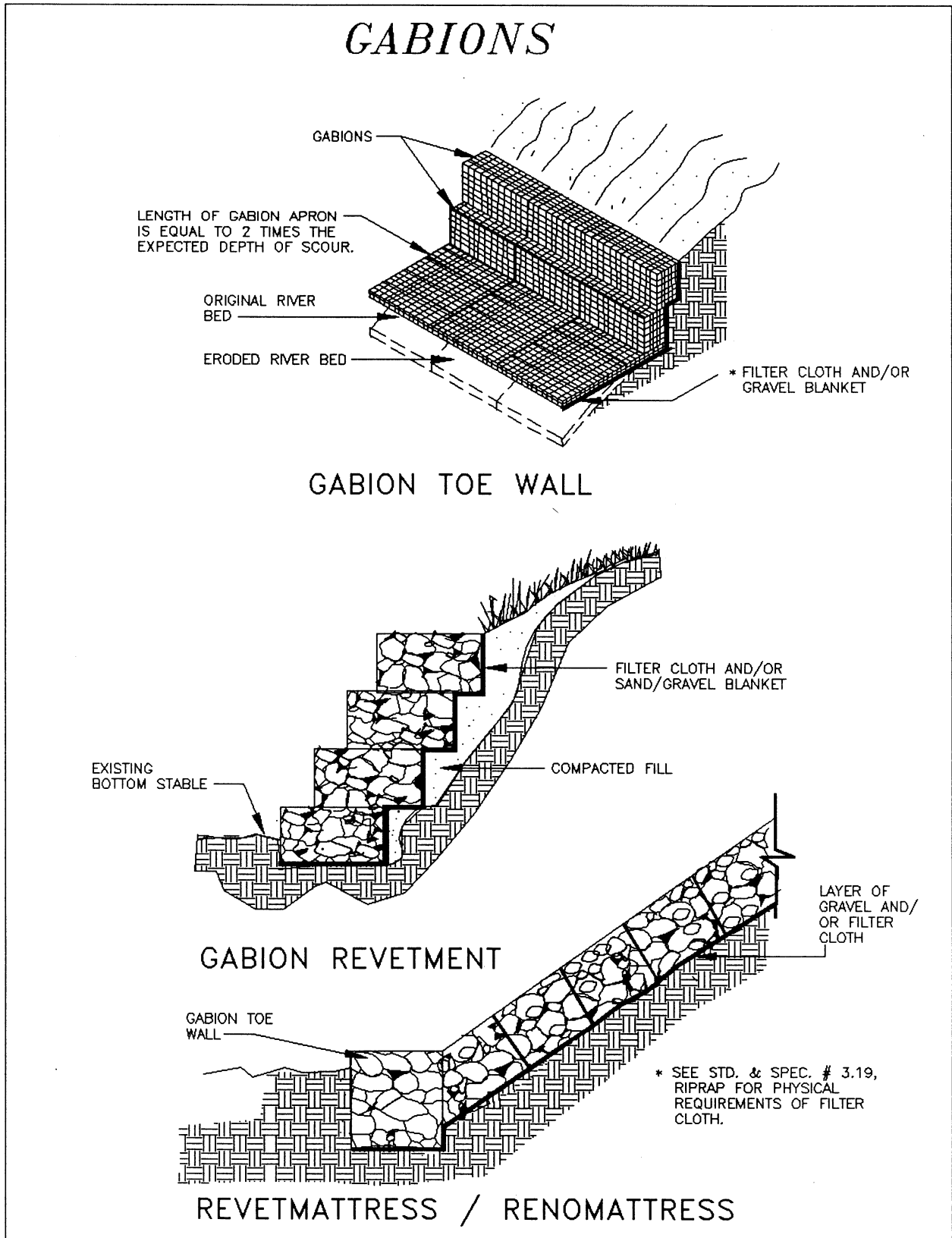

Source: Adapted from product literature of Bekaert Gabions

Plate 3.23-1

DEFLECTORS

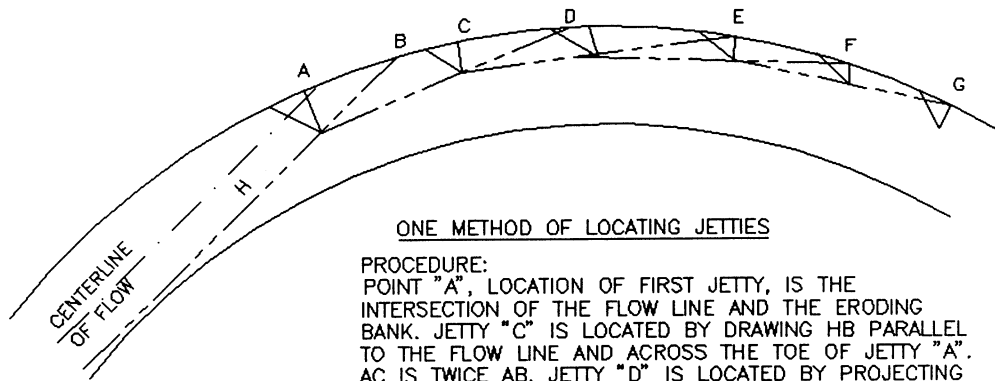

ONE METHOD OF LOCATING JETTIES

PROCEDURE:
 POINT "A", LOCATION OF FIRST JETTY, IS THE INTERSECTION OF THE FLOW LINE AND THE ERODING BANK. JETTY "C" IS LOCATED BY DRAWING HB PARALLEL TO THE FLOW LINE AND ACROSS THE TOE OF JETTY "A". AC IS TWICE AB. JETTY "D" IS LOCATED BY PROJECTING A LINE ACROSS THE TOE OF JETTIES "A" AND "C". THE REMAINING JETTIES ARE LOCATED THE SAME AS "D". SUPPLEMENTARY JETTY "K" IS LOCATED AC DISTANCE UPSTREAM FROM "A".

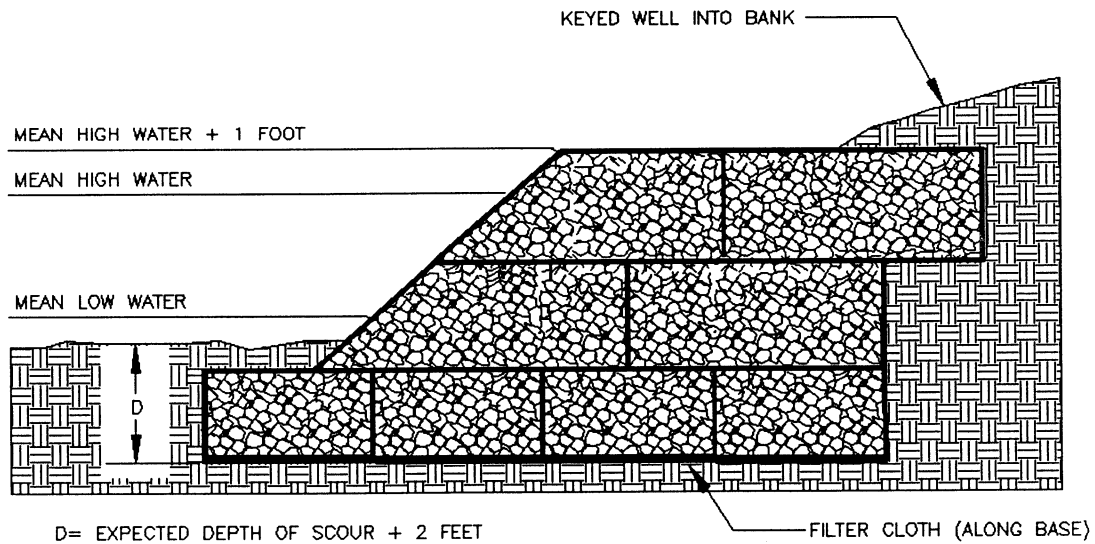

TYPICAL GABION DEFLECTOR

Source: Adapted from product literature of Bekaert Gabions

Plate 3.23-2

LOG CRIBBING

NOTE: STRUCTURE IS BUILT TO LEAN INTO THE BANK FOR STABILITY.

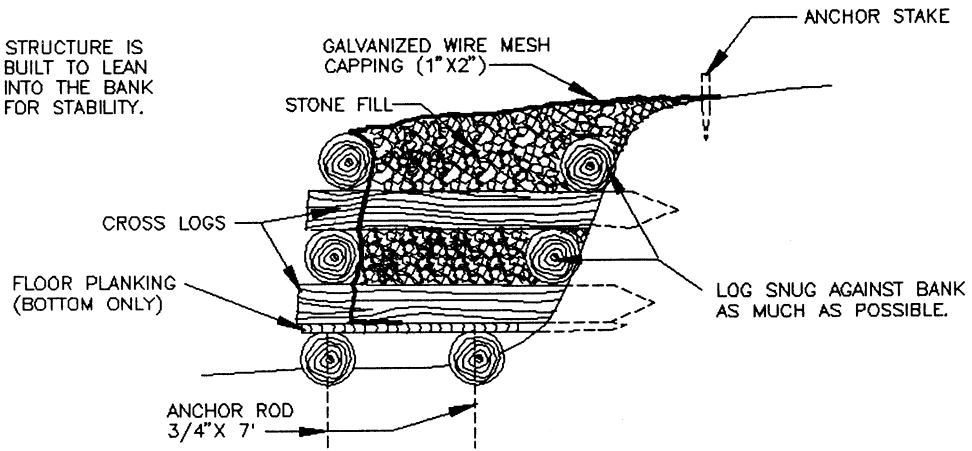

SIDE VIEW

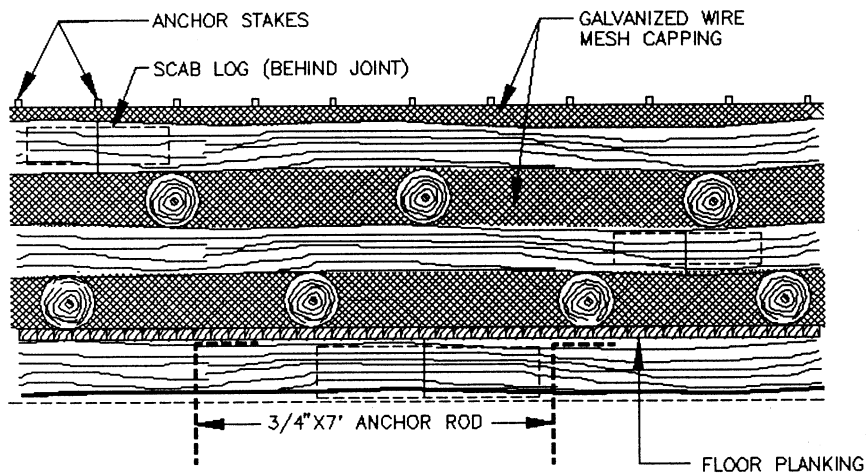

FRONT VIEW

GRID PAVERS

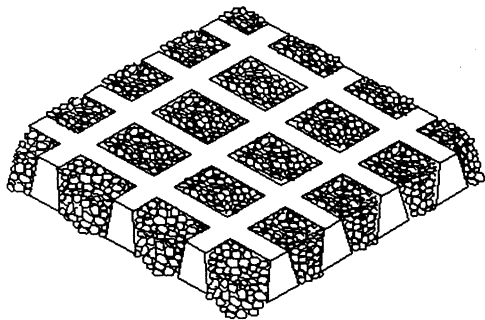

LATTICE UNIT

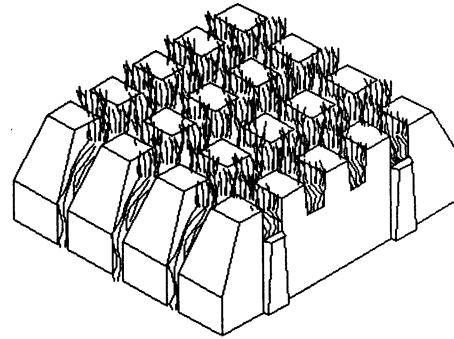

CASTELLATED UNIT

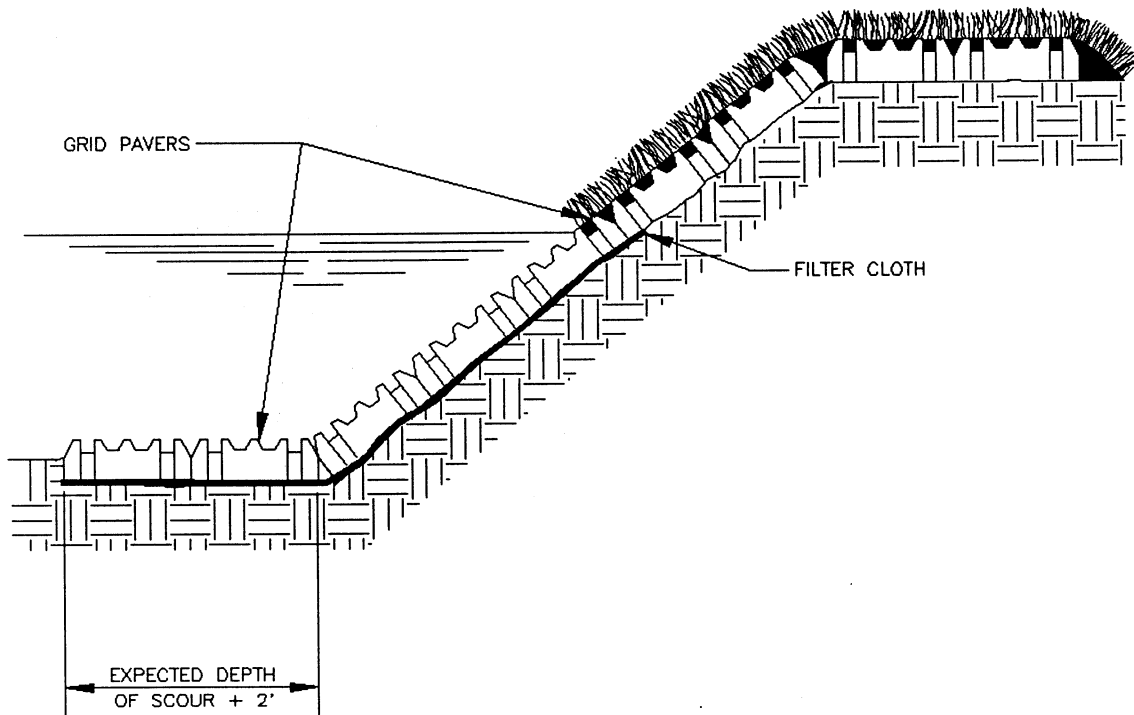

Source: Va. DSWC

Plate 3.23-4